



LWP Engineering s.r.l.

PI e CF 02538780343 - Via Berlinguer, 6 - 43038 Sala Baganza (Parma)

Tel e Fax: +39 0521/834833 Cell. : +39 348/5854760

E-mail : info@lwpengineering.com

www.lwpengineering.com

SCHEMA MOLLA / SPRING LAYOUT / FICHE RESSORT

SEZIONE RETTANGOLARE / RECTANGULAR SECTION / SECTION RECTANGULAIRE

RICHIESTA / REQUEST / DEMAND :

- OFFERTA / OFFER / DEVIS
- ORDINE / ORDER / ORDRE

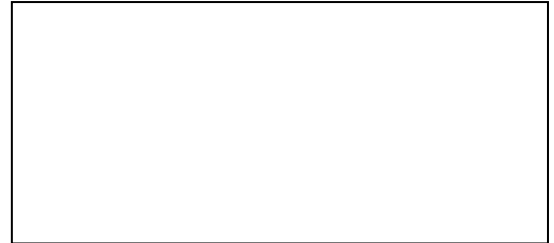

DITTA / COMPANY / SOCIETE'

QUANTITA' / Q.TY / QUANTITE' : N° _____

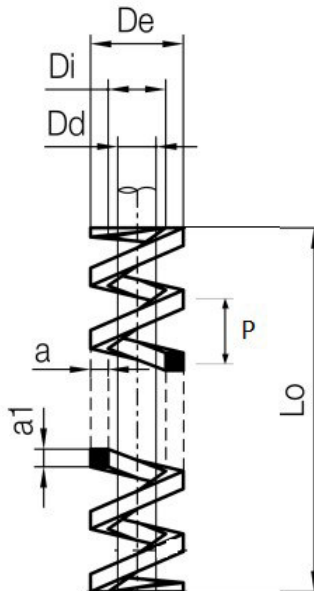

CARATTERISTICHE / SPECIFICATIONS / CARACTERISTIQUES

a / a1 = DIM. FILO / DIM. WIRE / DIM FIL : _____/_____

De = Ø ESTERNO / Ø OUTSIDE / Ø EXTERIEUR : _____

Di = Ø INTERNO / Ø INSIDE / Ø INTERIEUR : _____

P = PASSO / WIRE STEP / PAS : _____

L0 = LUNGHEZZA / LENGHT / LONGHEUR : _____

ST. = N° DI SPIRE / WIRE NUMBER / N° SPIRES : _____

ESTREMITA' / ENDS / EXTREMITES :

- MOLATE / GROUNDED / MEULEES RAVVICINATE / CLOSED / RAPPROCHEES

MATERIALE / MATERIAL / MATERIEL :

- INOX / STAINLESS STEEL / INOX AISI 302
- ACCIAIO / STEEL / ACIER _____